

# **Technical Drawings**

Clara Swagel

# **Flats for Halston**

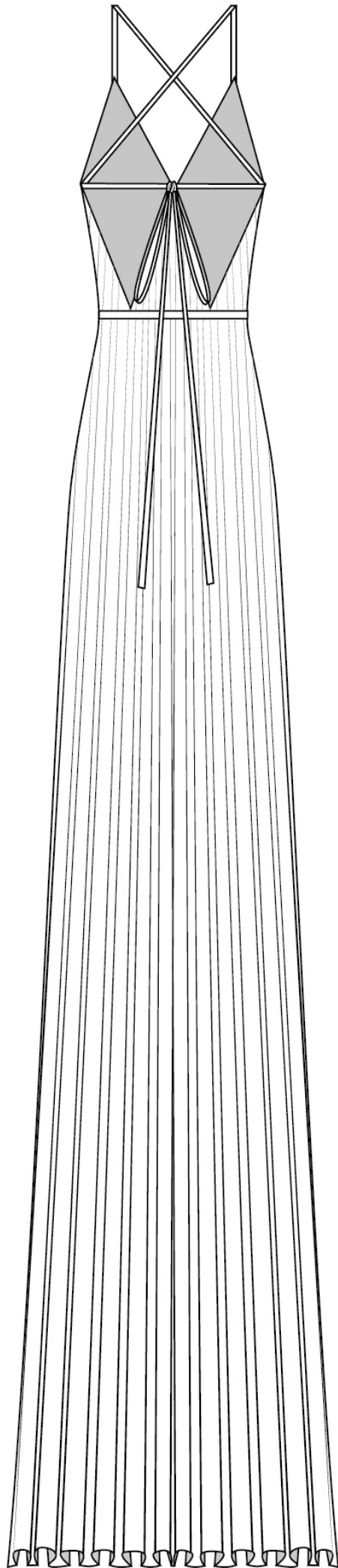

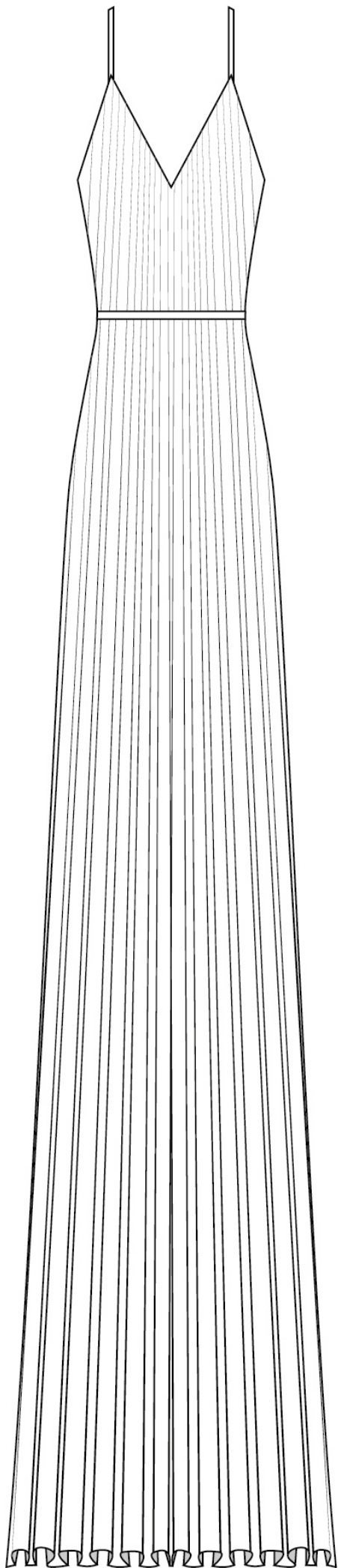
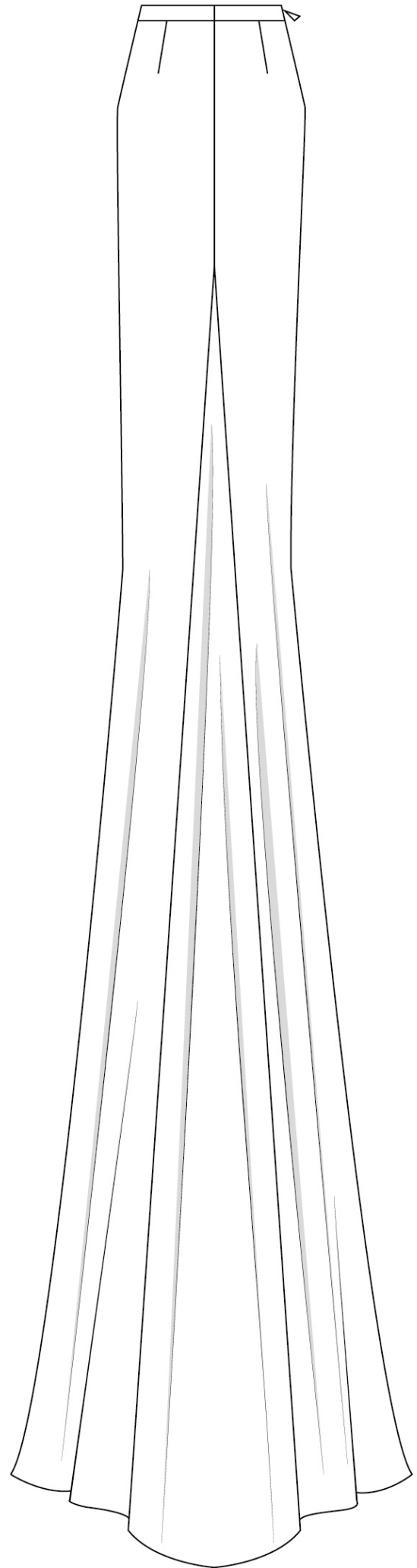
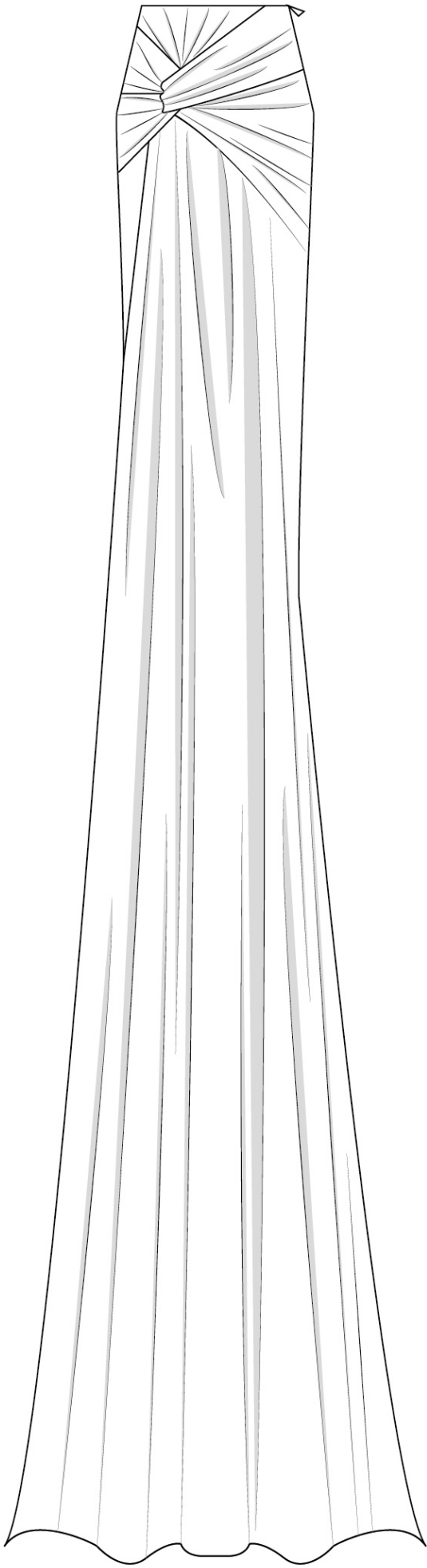

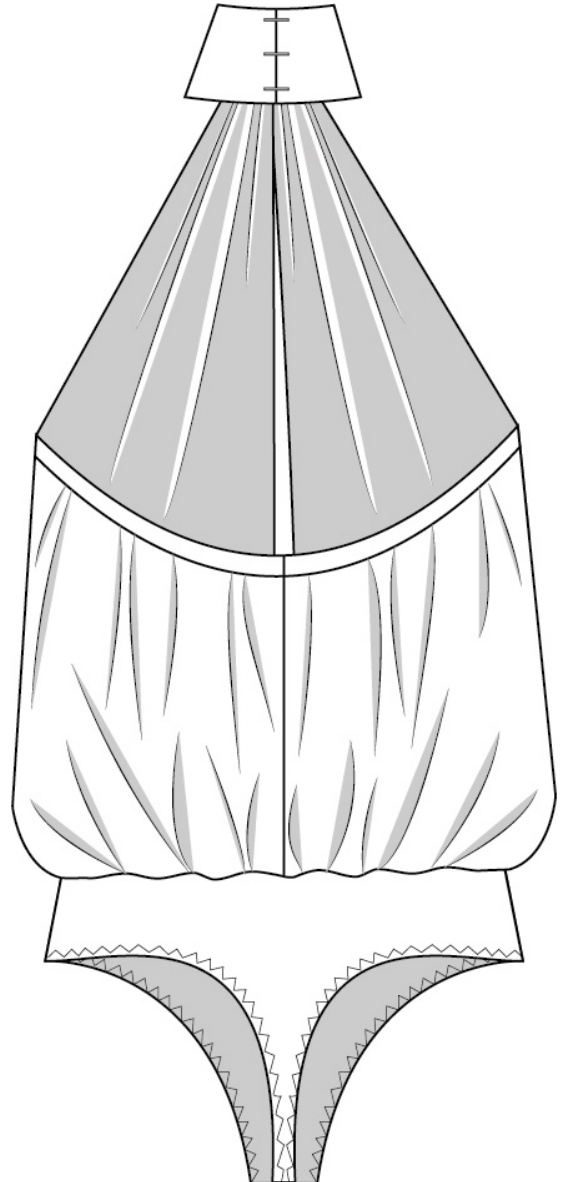
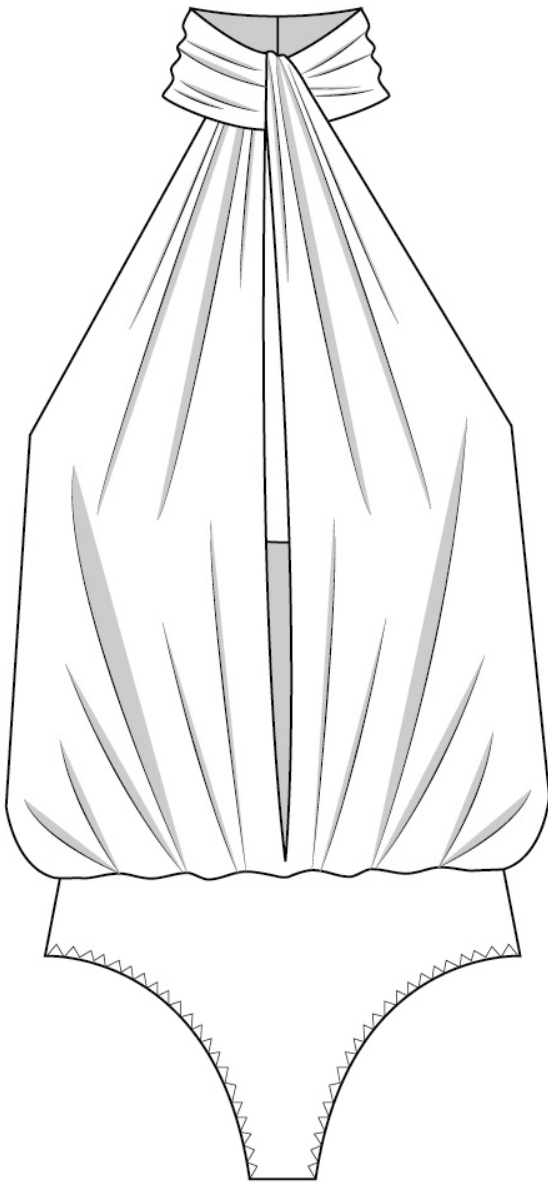

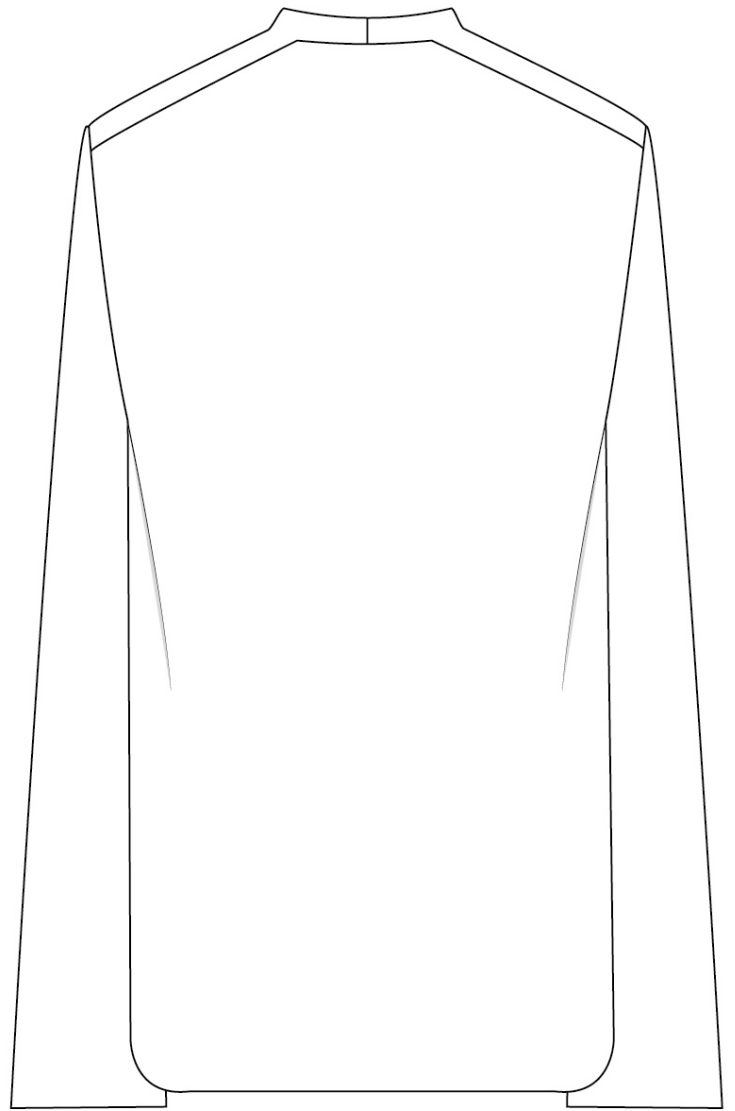
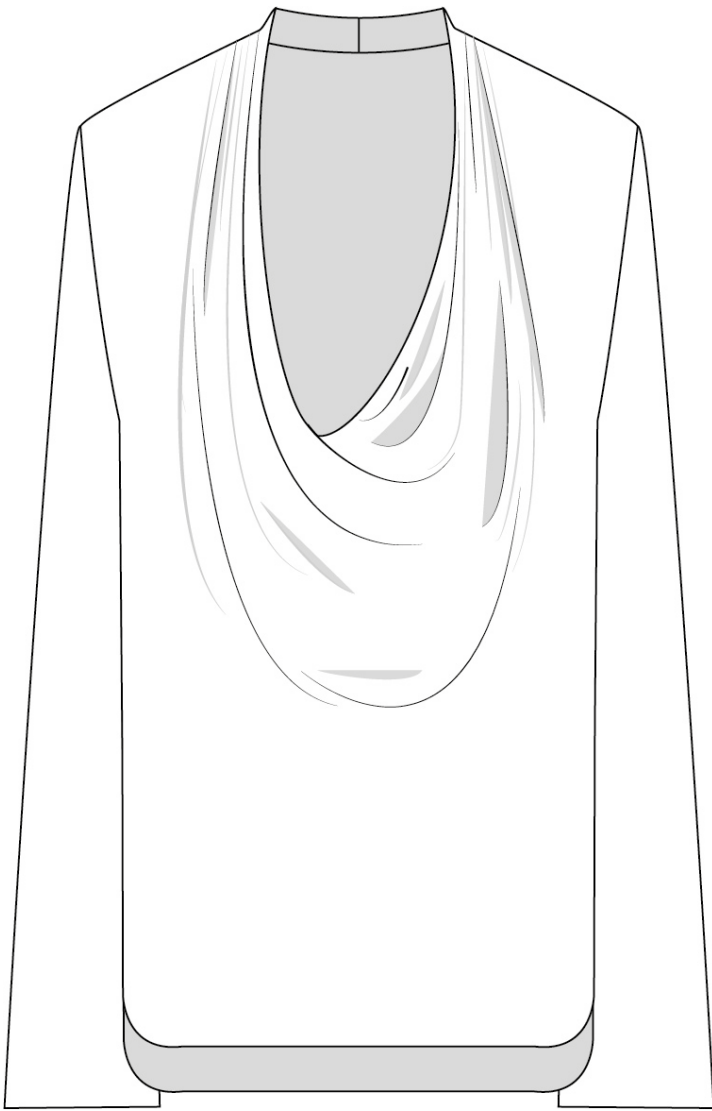

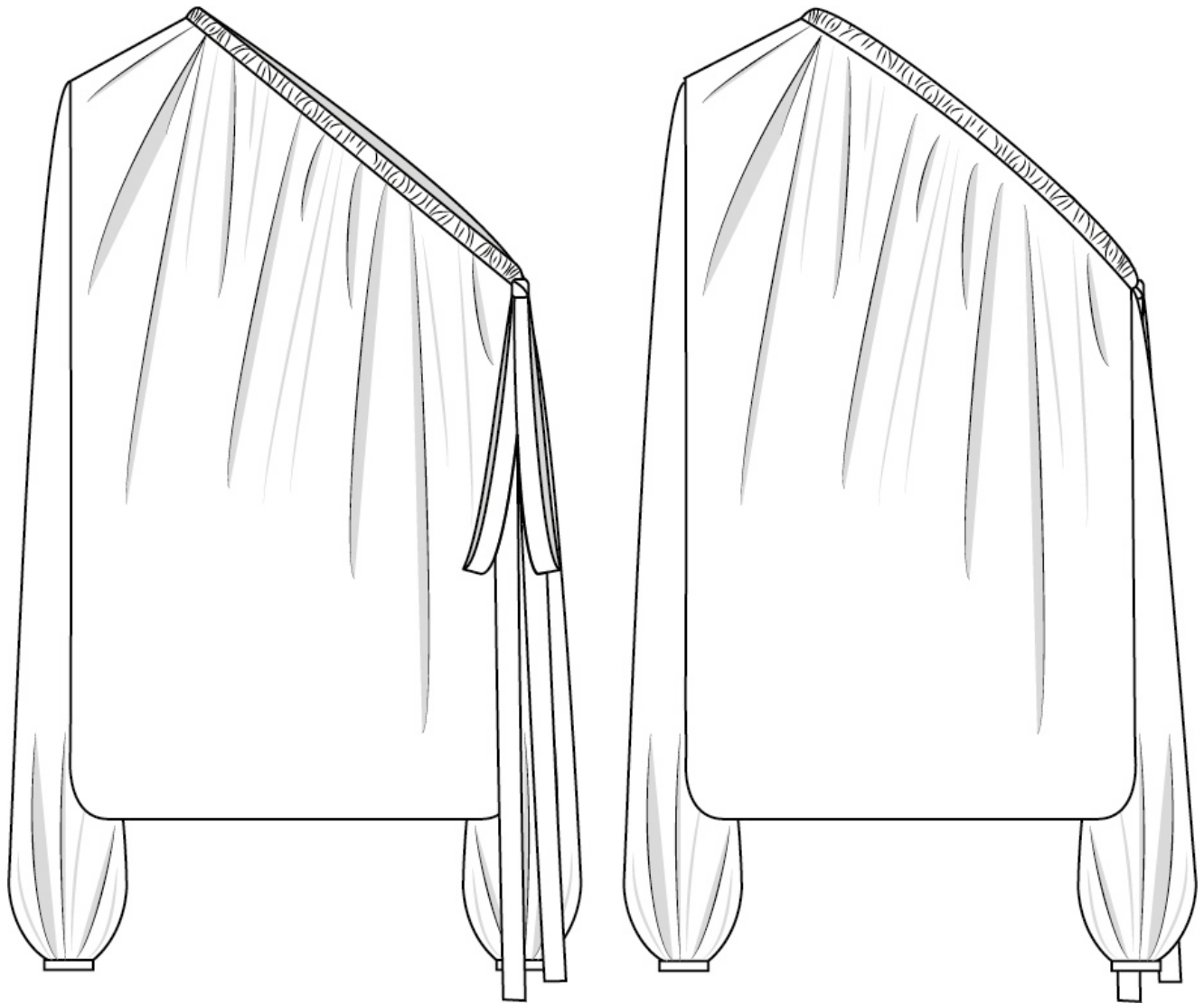

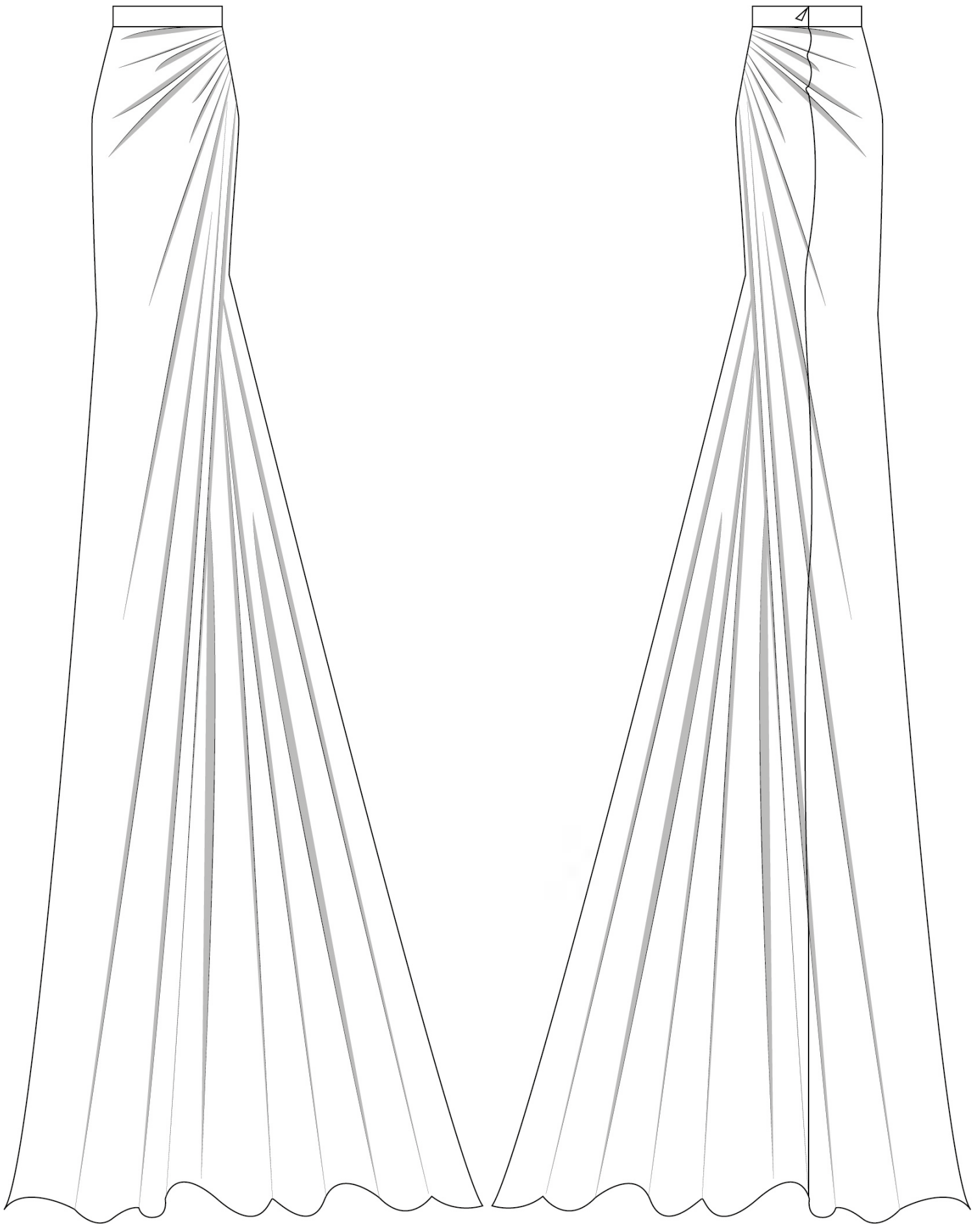



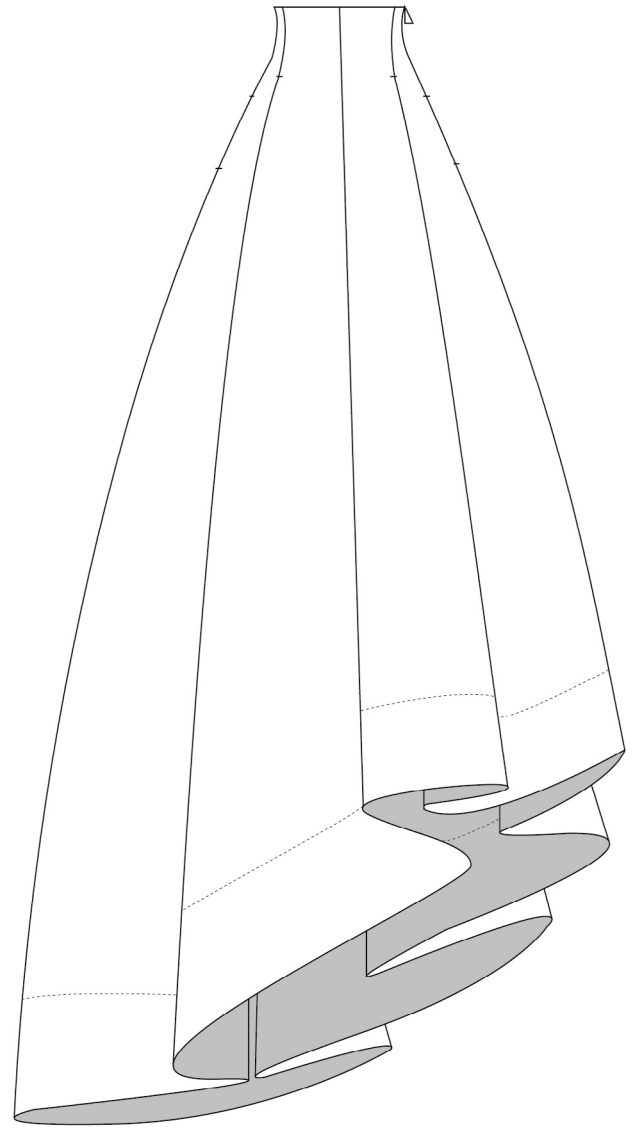
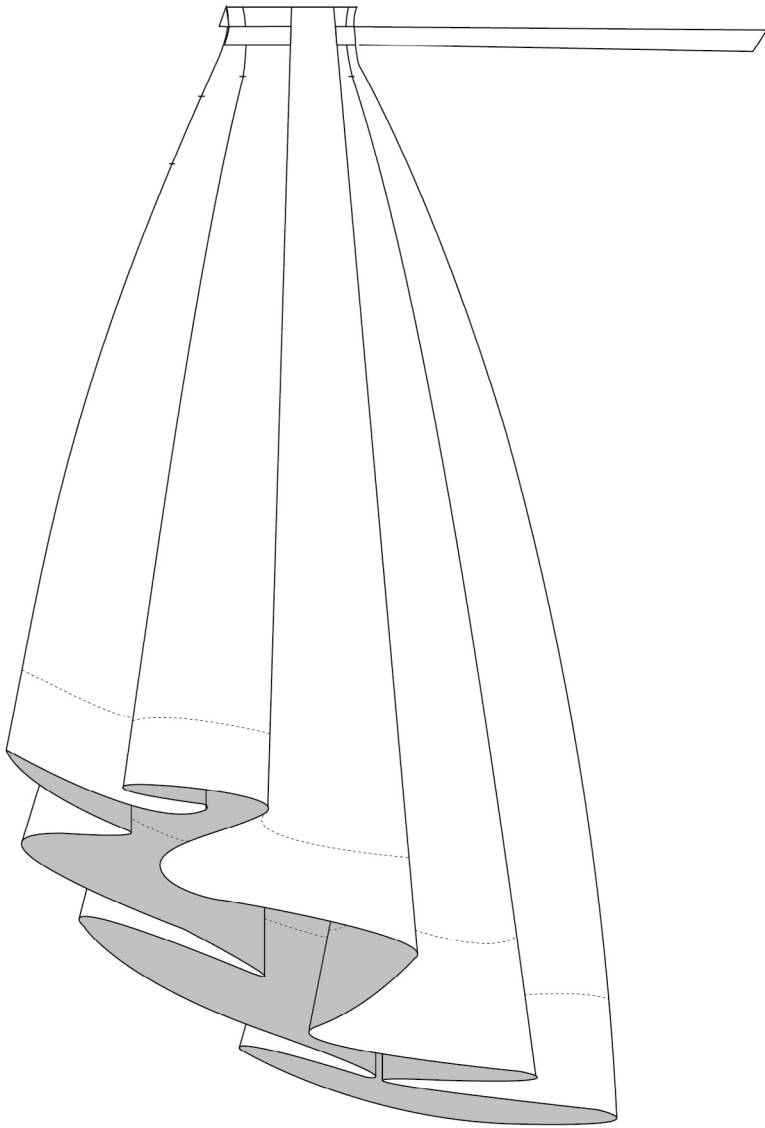
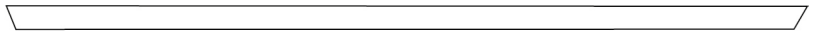

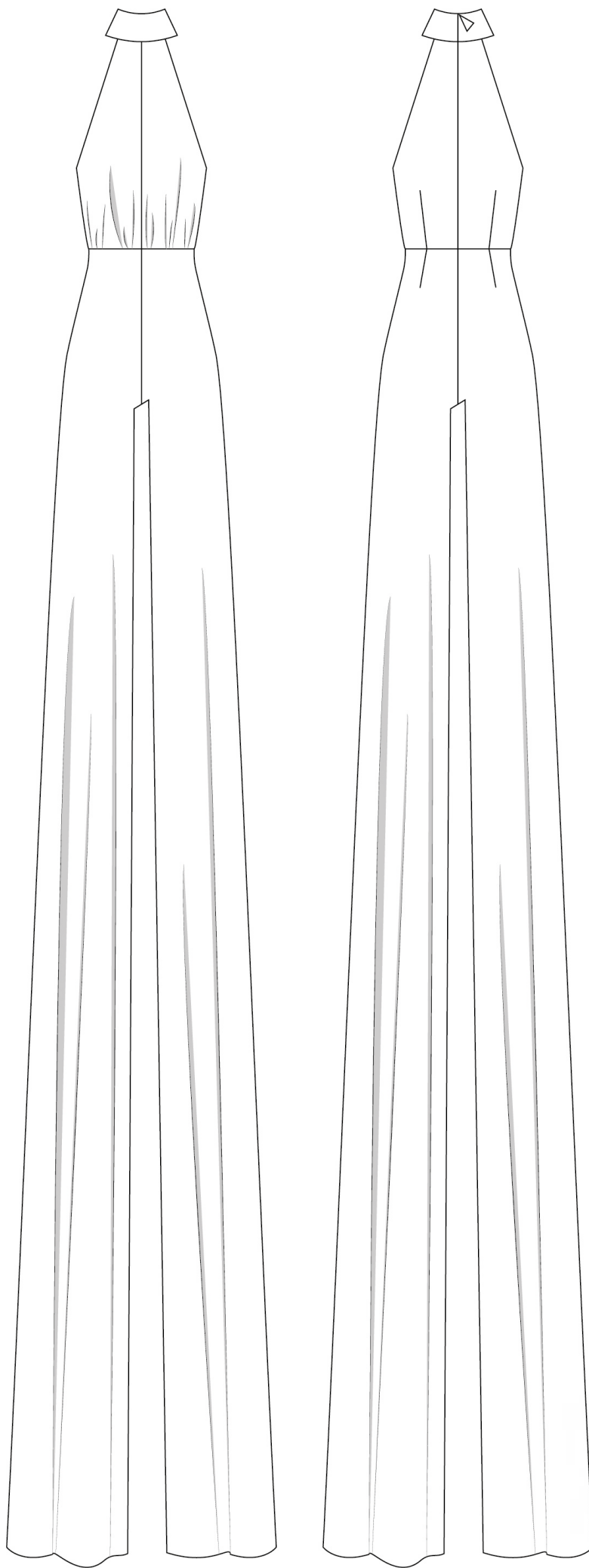

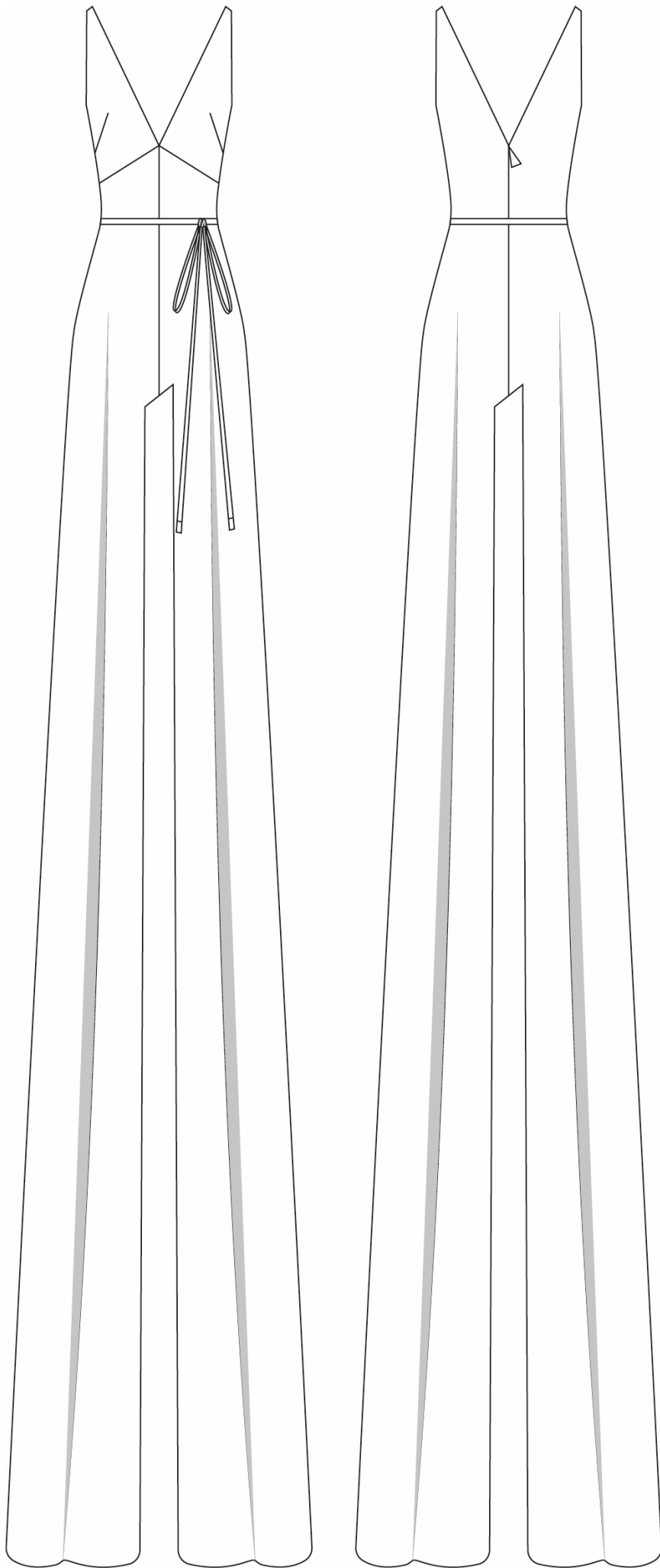

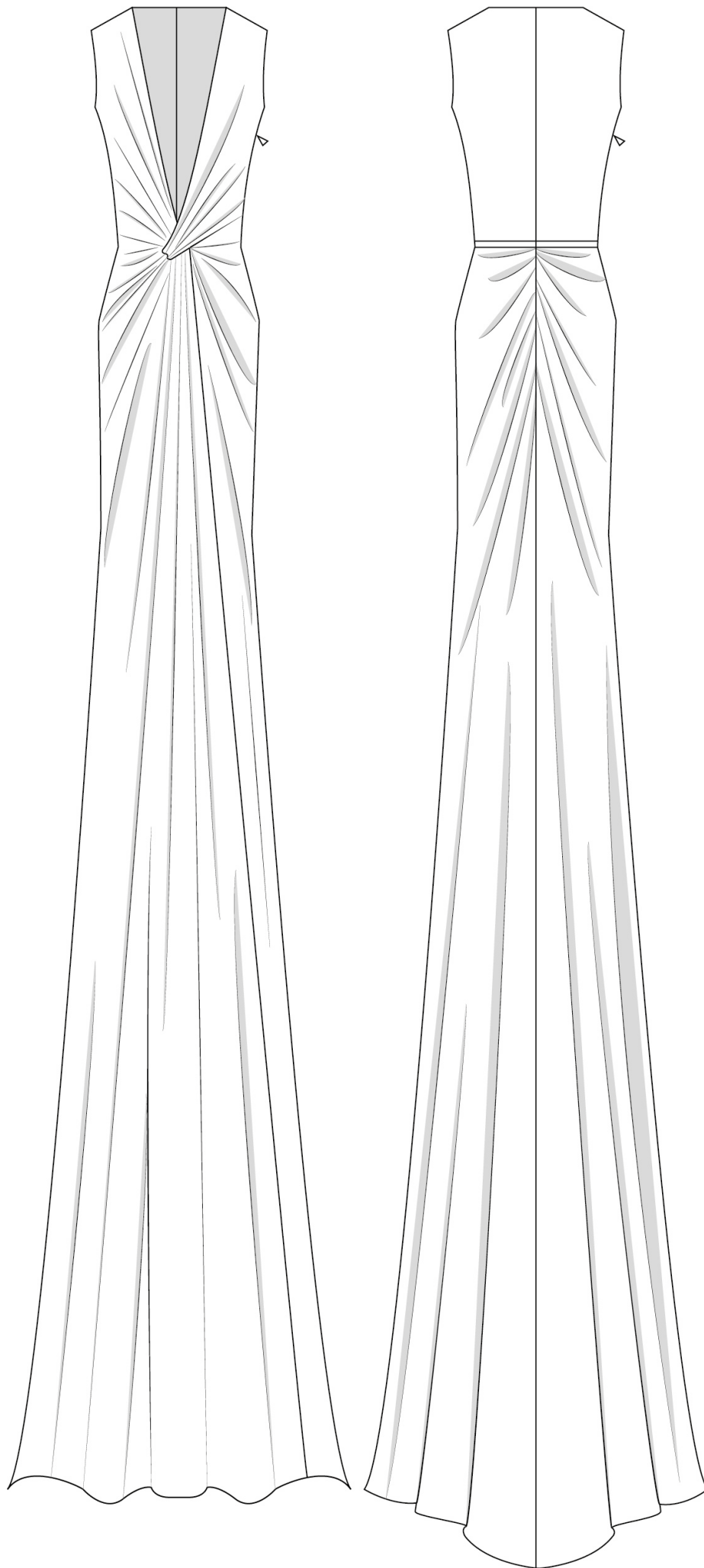

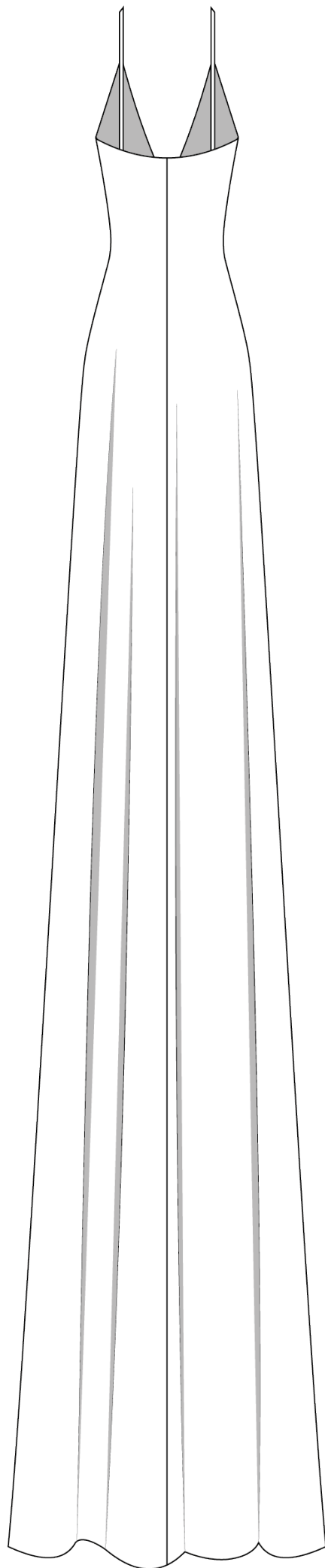
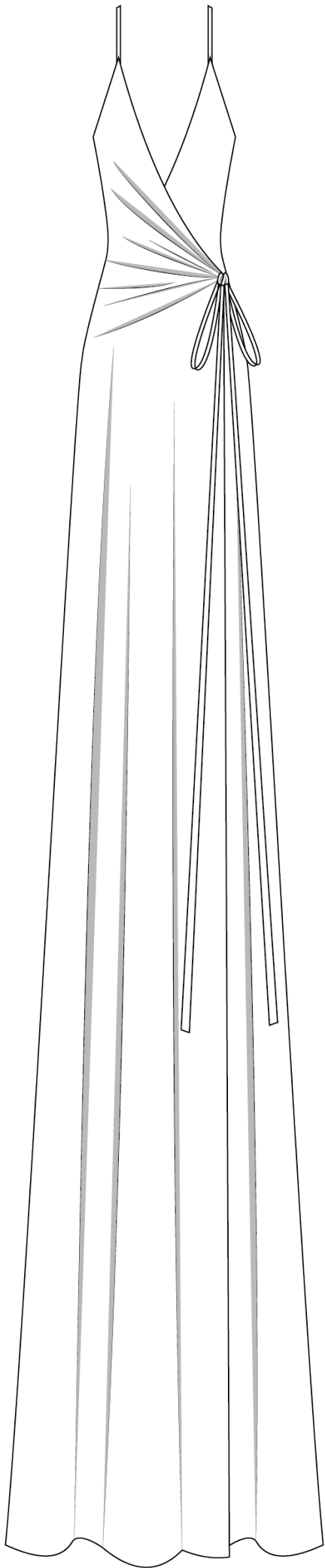

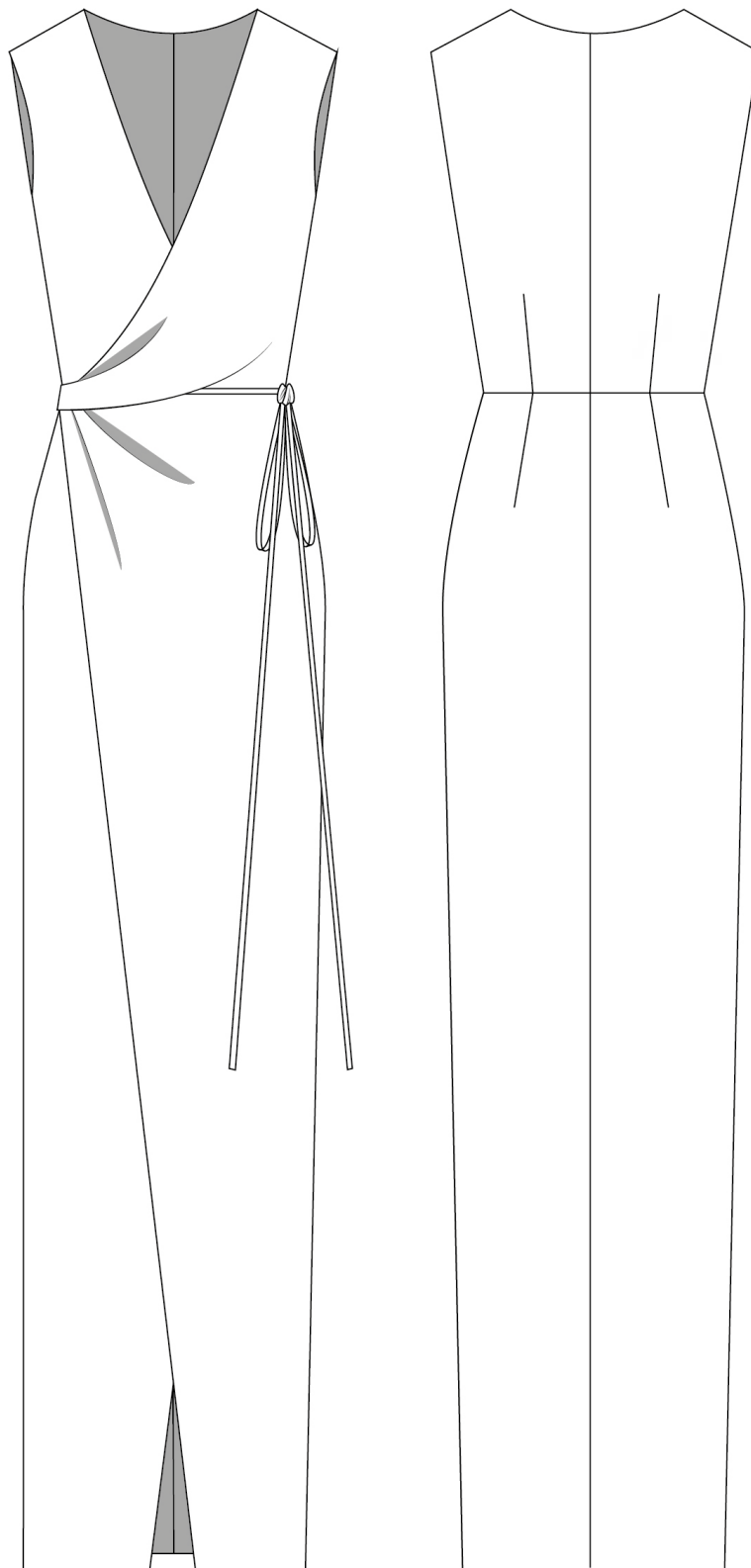

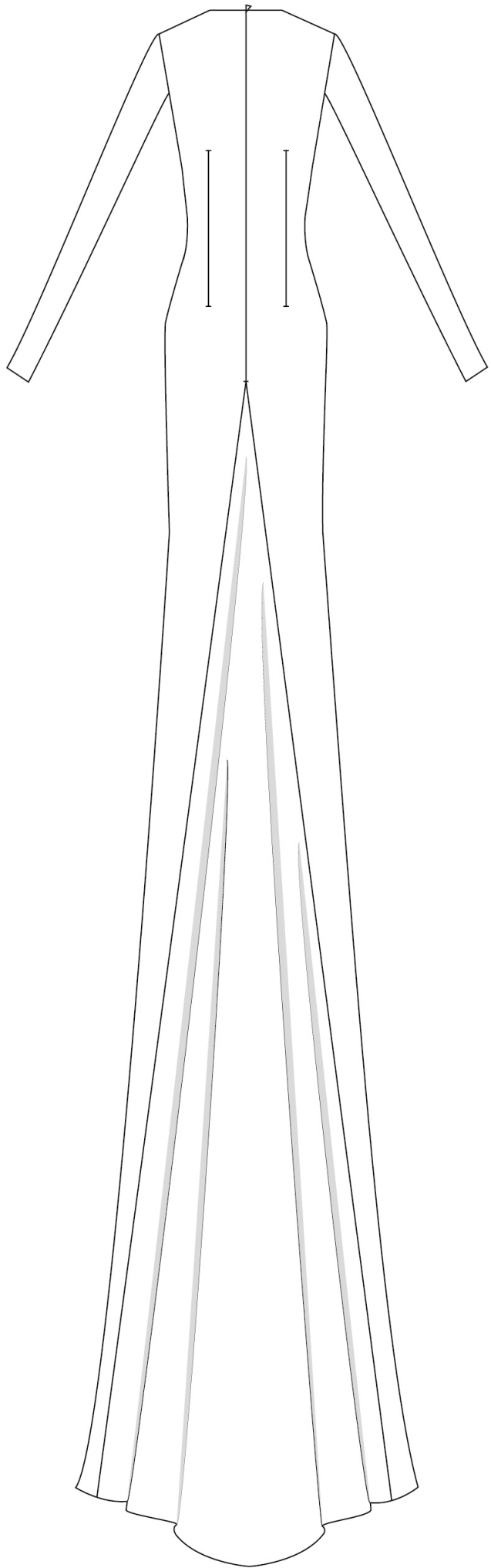
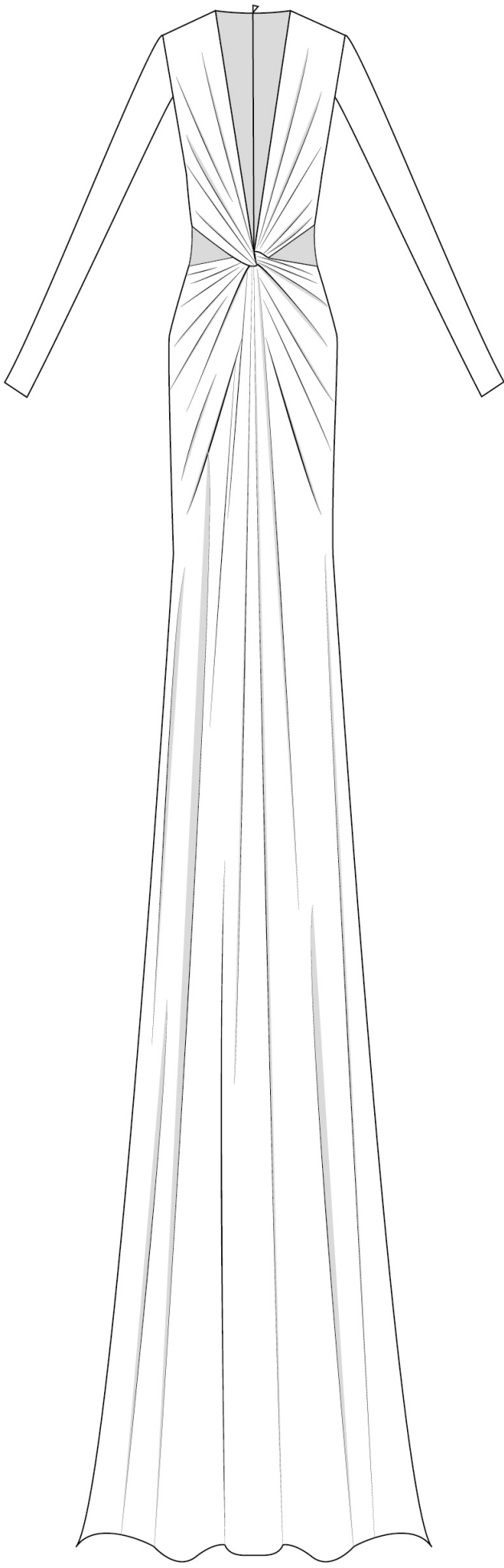

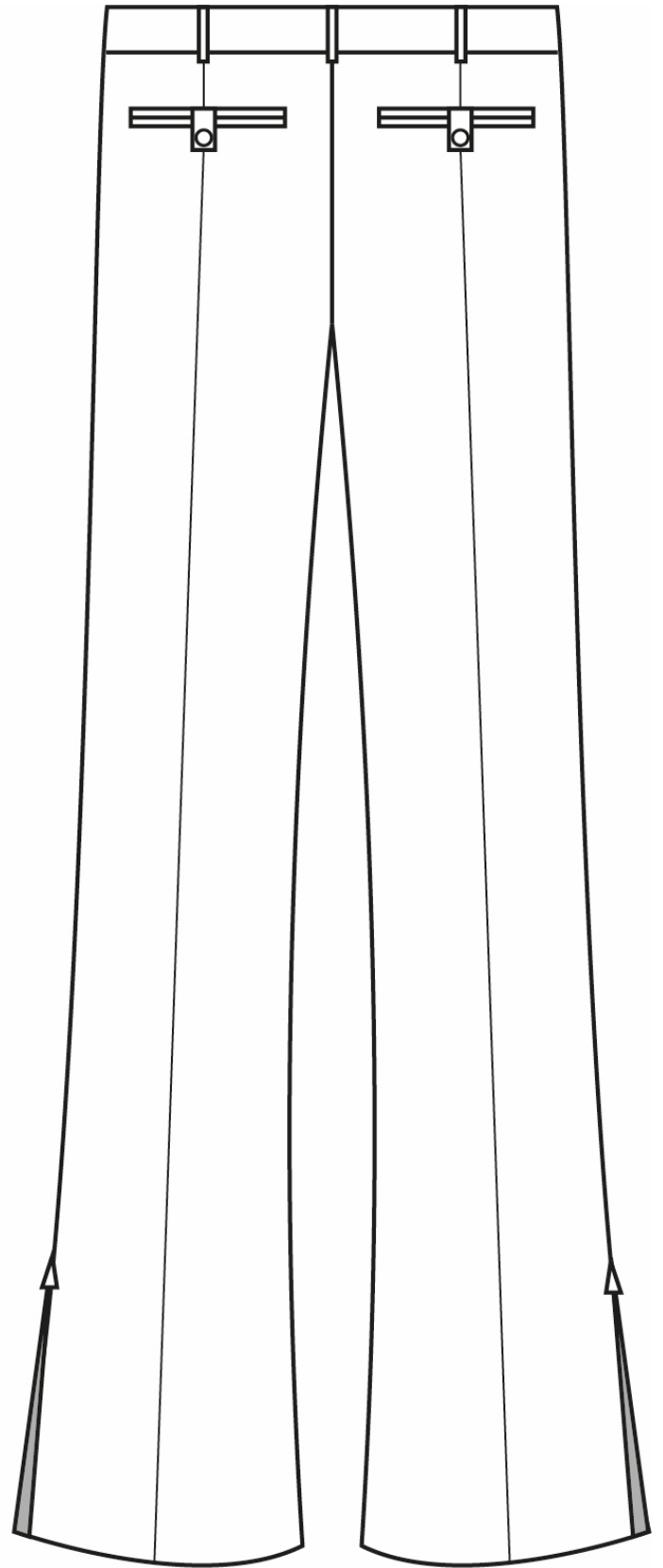
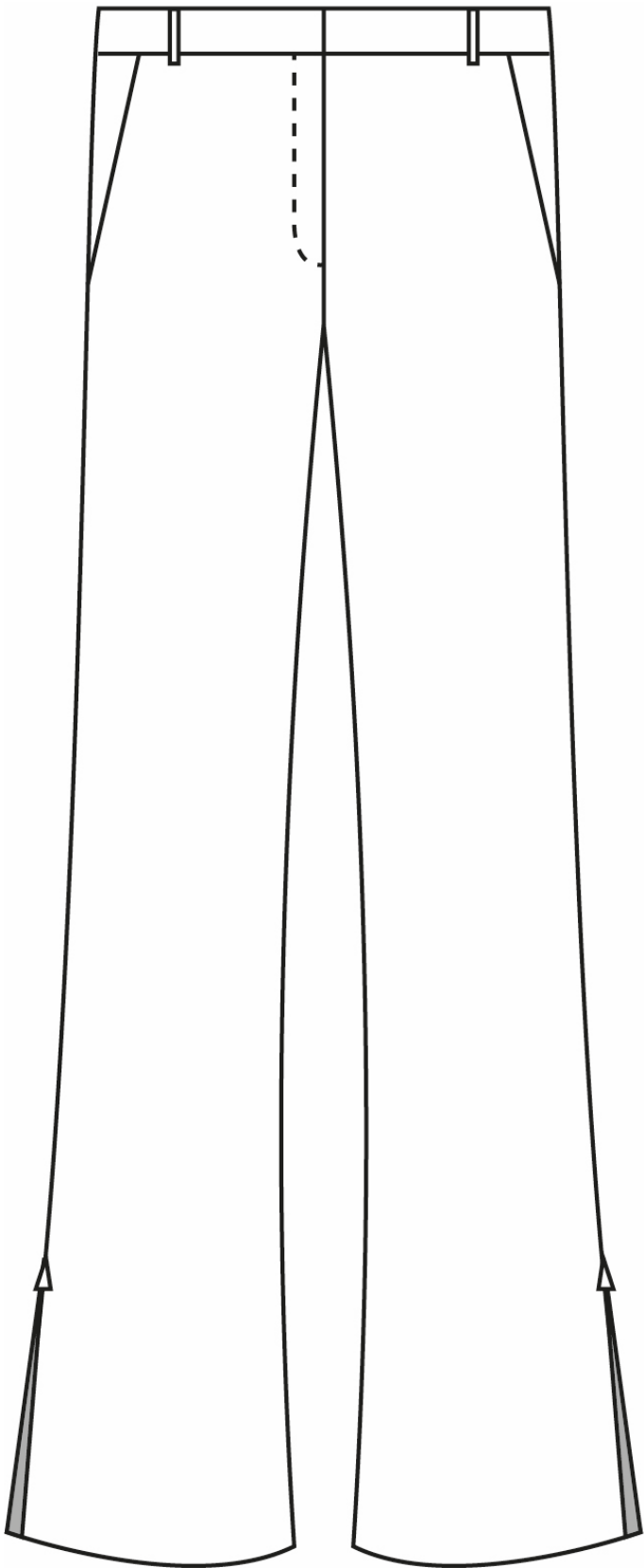



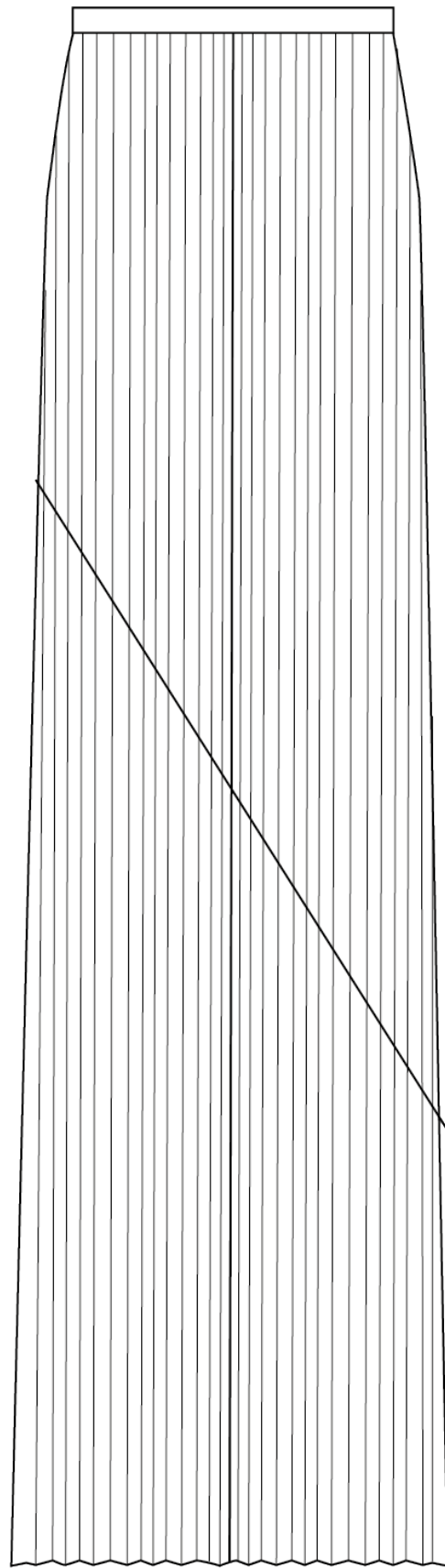
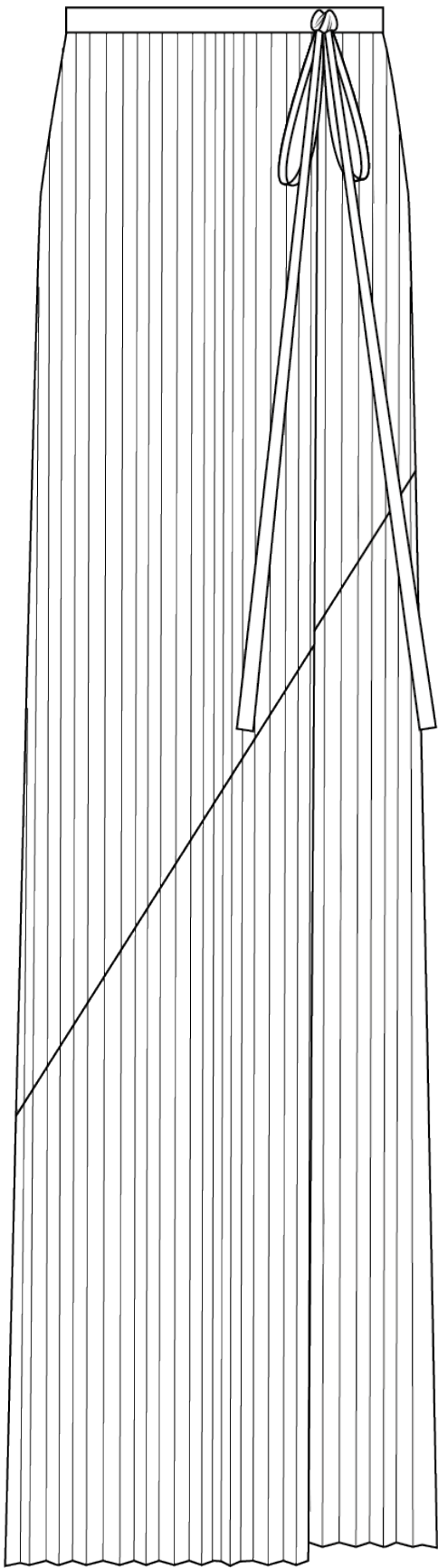



# **Flats for Line in the Sand by Kay Unger**

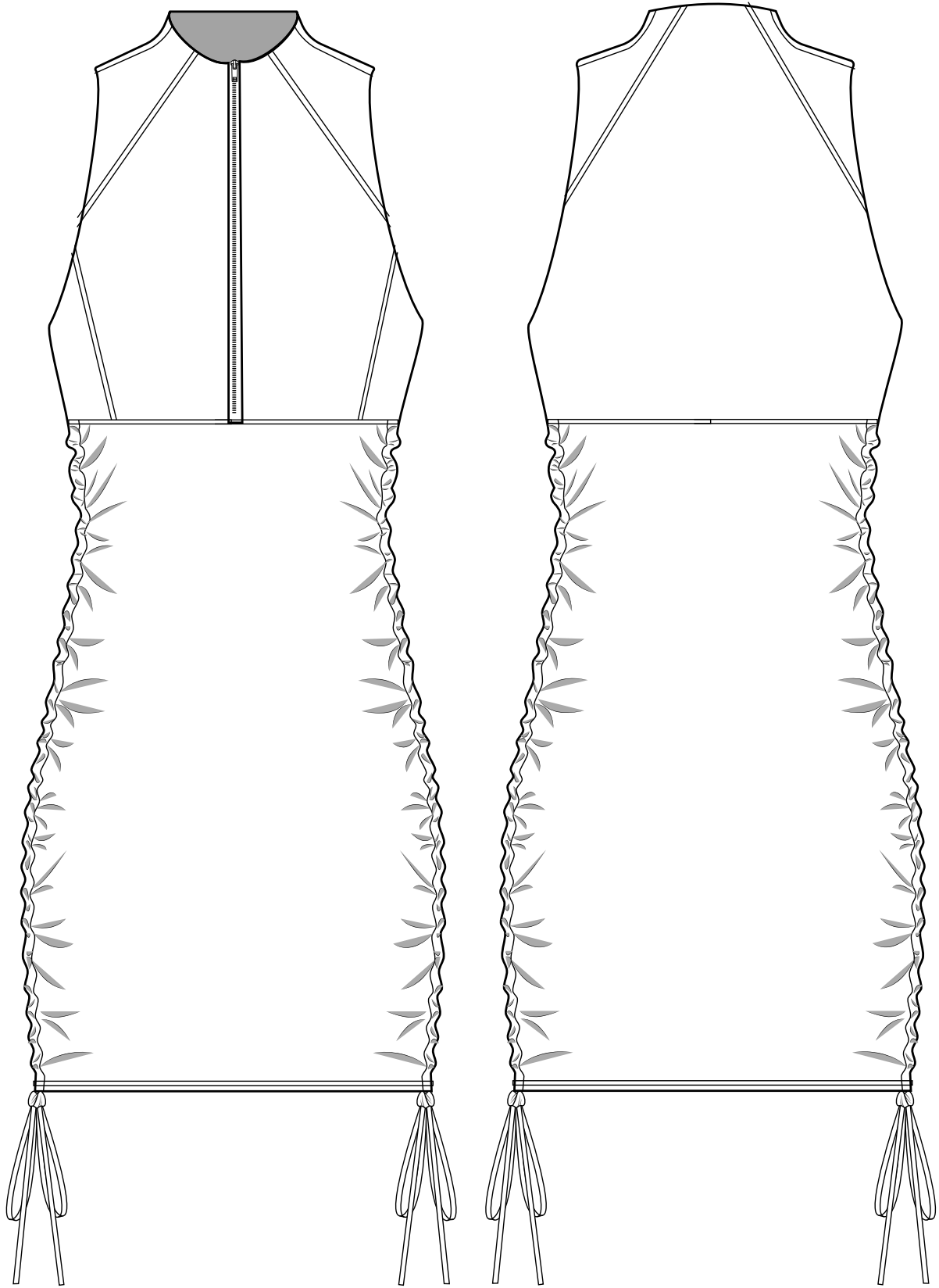

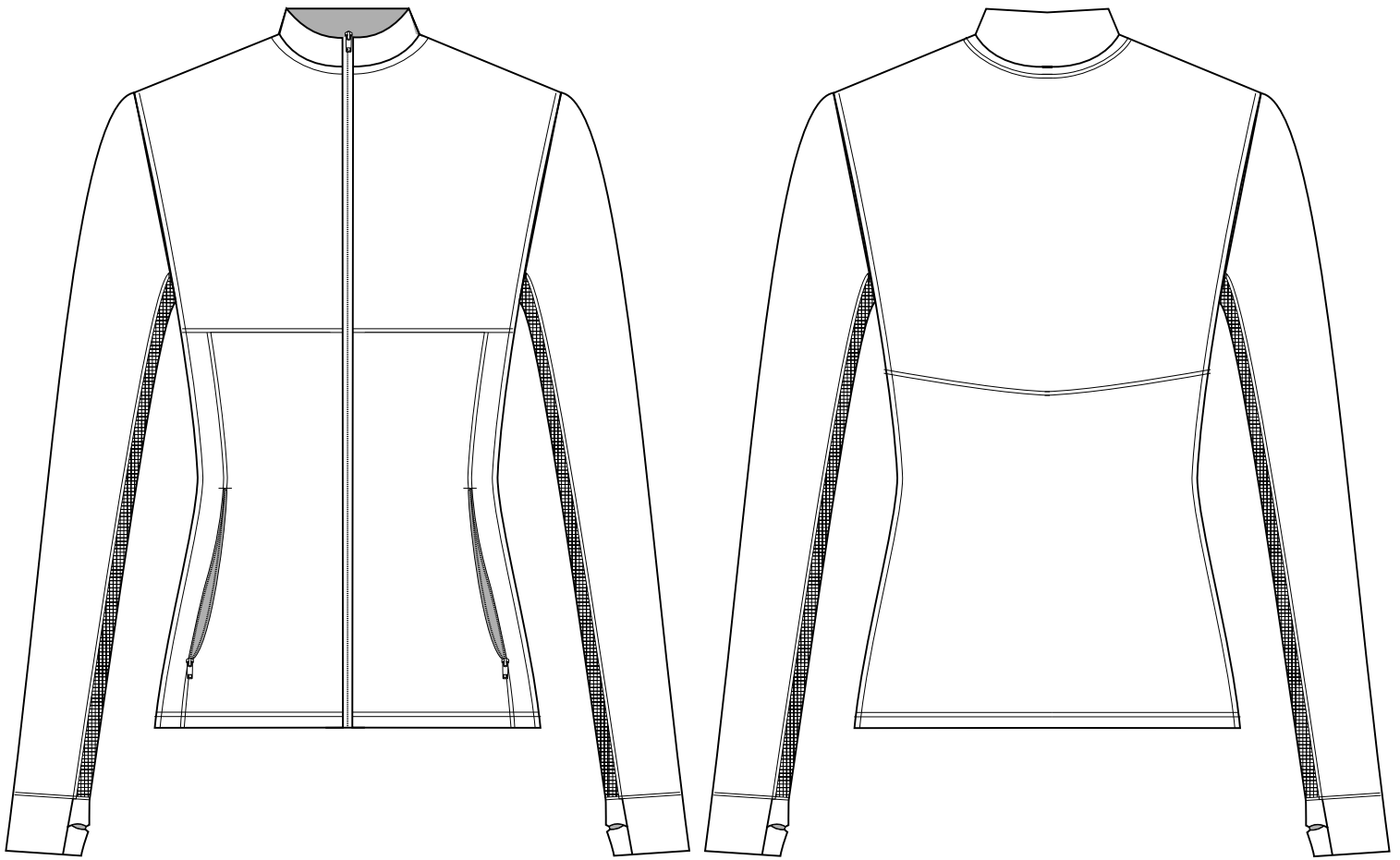

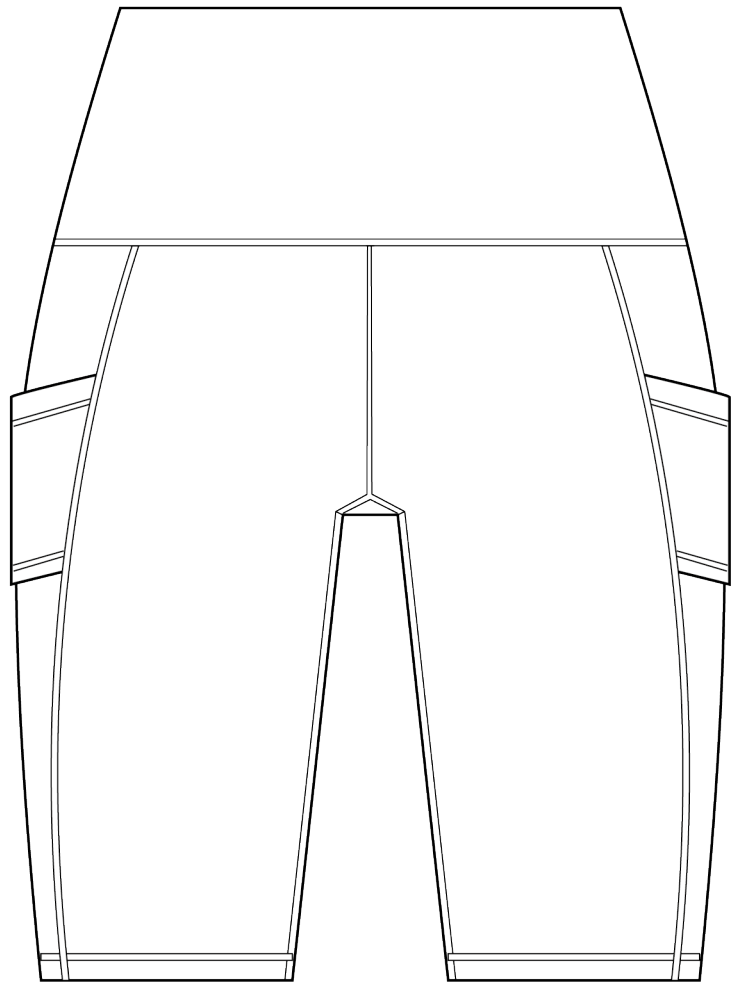
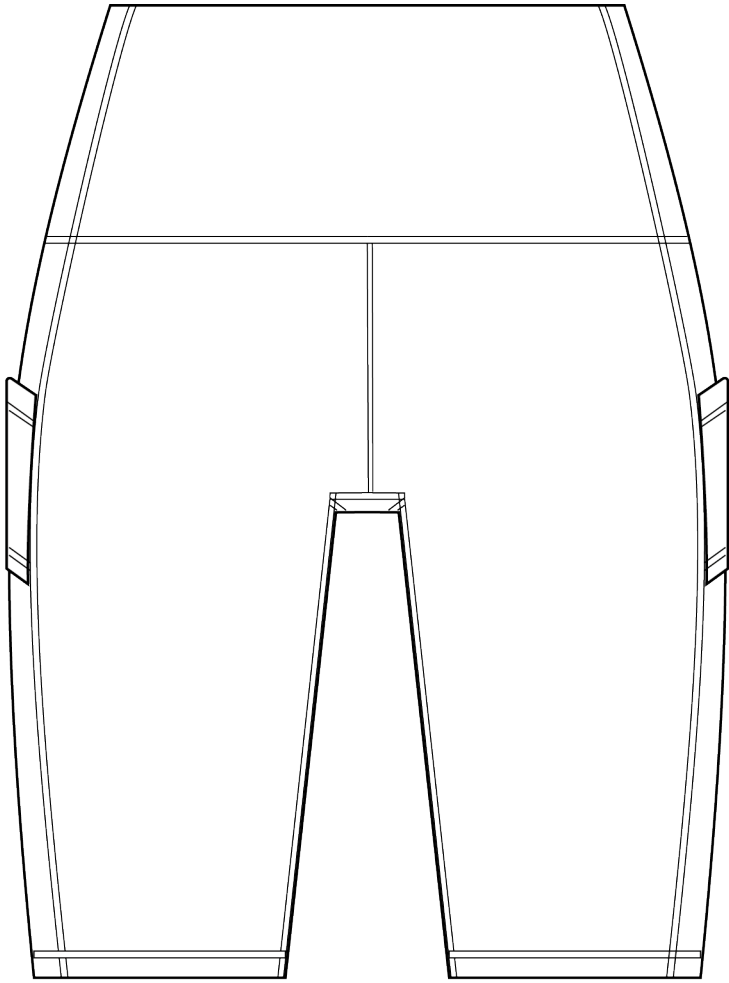

# **Flats for my Personal Work at Parsons**

